

1

Slotted Joint Cockpit

2

Dovetail Joint Arm

3

Inset Front Fastener

4

Pegged Bookends

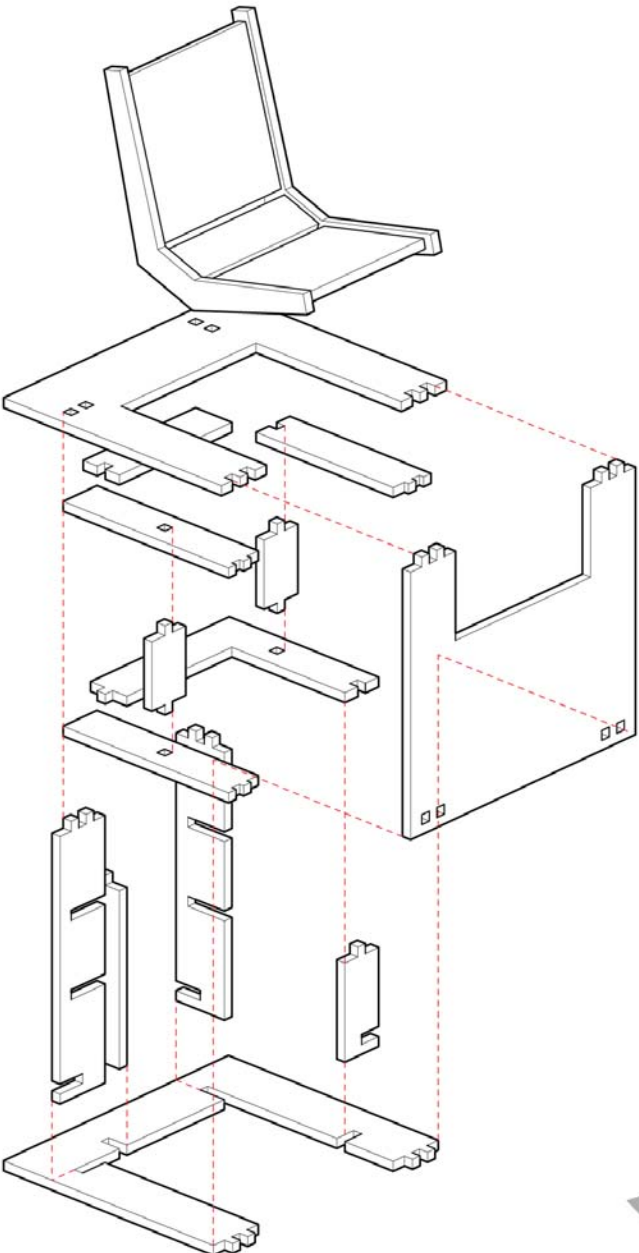



**chair  
bookcase**  
**bookcase  
chair**  
case study 22  
photo Julius Shulman

